

K29-3775

500 - 875 HP Turbo

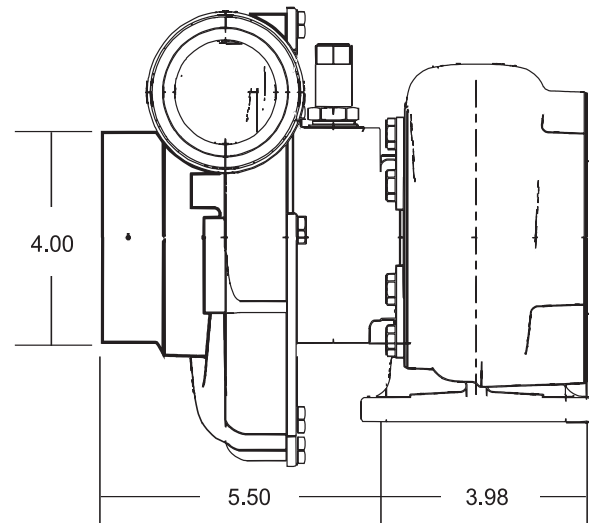

Turbo Frame Dimensions

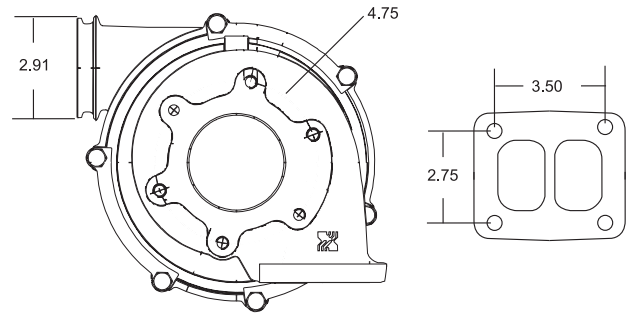

Turbo Features

- Twin hydrodynamic journal bearings
- Forged milled compressor wheel
- Twin scroll turbine housing
- Adjustable compressor and turbine housing orientation
- Compact design

Compressor Map

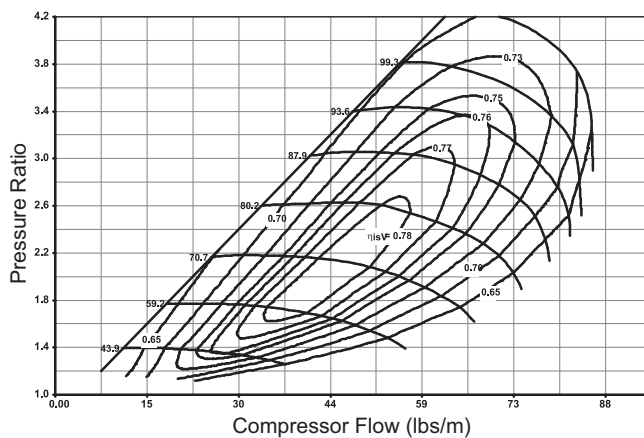

Utilizing Forged Milled Compressor Wheel (FMW) Technology

- Stronger Than Cast Wheels
- Higher Pressure Ratio
- Resists High Cycle Fatigue



Turbo Part Number	Comp. Wheel O.D.	Comp. Wheel Inducer Dia.	Comp. Wheel Inducer Dia. (mm)	Turbine Wheel O.D.	Turbine Wheel O.D. (mm)	Turbine Wheel Exducer	Turbine Wheel Exducer (mm)	Turbine A/R	Cartridge Assembly	Service Kit
53299887120	3.70	2.79	70.93	3.23	82	2.80	71.00	17 ² cm	N/A	5331 711 0005