

K26

300 - 350 HP Turbo

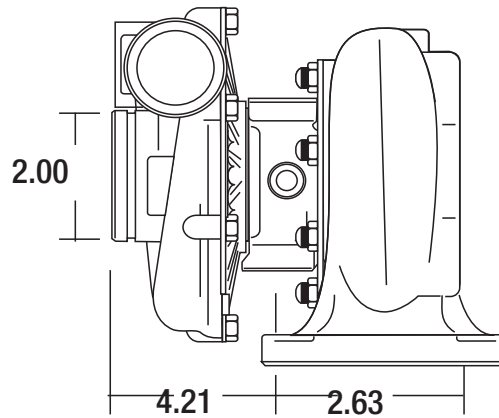

Turbo Frame Dimensions

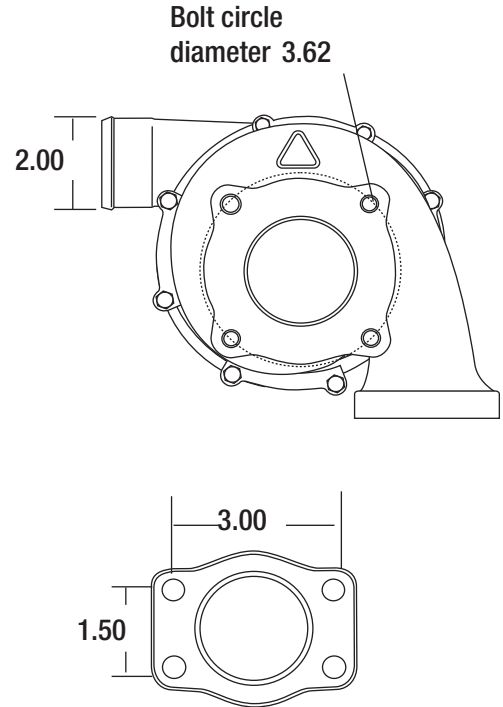

Turbo Features

- Twin hydrodynamic journal bearings.
- Open volute design
- Adjustable compressor and turbine housing orientation
- Compact design
- High temperature alloy turbine housing

Compressor Map

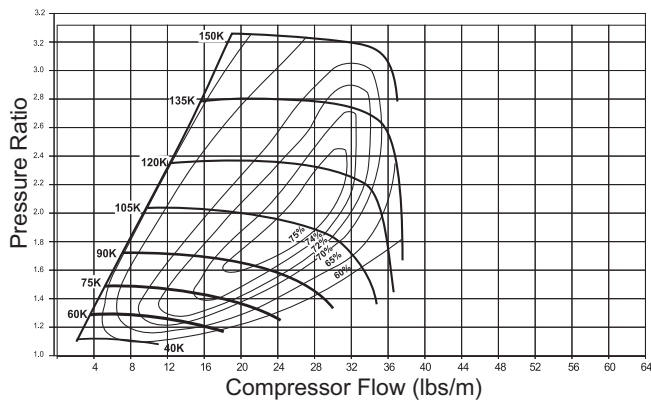

Turbo Part Number	Comp. Wheel O.D	Comp. Wheel Inducer Dia.	Comp. Wheel Inducer Dia. (mm)	Turbine Wheel OD	Turbine Wheel Exducer	Turbine Wheel Exducer (mm)	Turbine A/R	Cartridge Assembly	Service Kit
5326-988-6720	2.60	1.73	44	2.52	1.88	48	6 ² cm	5326 710 0507	5326 711 0501
5326-988-7042	2.60	1.80	46	2.52	2.17	55	8 ² cm	5326 710 0522	5326 711 0501